



MEMS Capacitive Accelerometers

## Data sheet

### MS7000.3

30S.MS7X.1.08.07

#### Features

**Good bias stability for high bandwidth**  
**± 2g, ±10g Full scale range**  
**High shock**  
**Low cost for advanced specifications**  
**Low power analog voltage output**  
**TO8 packaging**

#### Applications

**Vibration sensing**      Data logger  
                                          HUMS  
                                          Structure monitoring  
**Inertial sensing**      Drilling (oil & gas)  
                                          Civilian avionics  
**Tilt sensing**            Instrumentation  
                                          Transportation

#### Description

Colibrys MS7000 accelerometers are ideal products for a wide range of applications in the domains of **vibration, inertia and tilt / inclination** sensing. The robust and low power design combined with an excellent bias stability and a relative high bandwidth guarantee the superior reliability of the MS7000 MEMS accelerometer.

The Colibrys MS7000 accelerometer is a MEMS capacitive sensor, based upon a bulk micro-machined silicon element, a low

power ASIC for signal conditioning and a micro-controller for storage of compensation values. The product is low power, calibrated, robust and stable.

Long-term stability of bias and scale factor are typically less than 0.1% of full-scale range. For the ±2g version (MS7002.3), typical bias temperature coefficient is ~ 100 µg/°C and scale factor temperature coefficients 100 ppm/°C for a bandwidth > 800Hz (at -3dB).

MS7000 side View

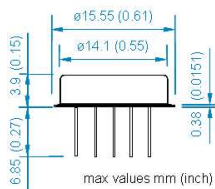

MS7000 top view

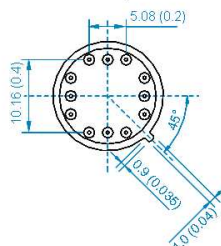

MS7000 side View

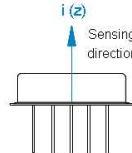

MS7000 top view

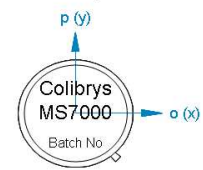

#### Specifications

All values are specified at +20°C (+86°F) and 3.0 VDC supply voltage, unless otherwise stated

	Units	MS7002.3	MS7010.3
Full scale range	g	± 2g	± 10g
Packaging		TO8, 12 pins	TO8, 12 pins
Bias calibration	mg	< 10	< 50
One year bias stability [1]	mg typ. (max.)	2 (< 5)	10 (< 25)
Bias temp. coefficient [3]	mg/°C typ.	0.1	0.5
	mg/°C max.	± 0.4	± 2
Scale factor sensitivity (K1)	mV/g	500 ± 4	100 ± 1
One year scale factor stability [2]	ppm typ. (max.)	500 (< 1000)	500 (< 1000)
Scale factor temp. coefficient [3]	ppm / °C typ.	100	100
	min. / max.	-50 / 250	-50 / 250
Input axis misalignment (Kp, Ko)	mrad max.	< 10	< 10
	% max	1	1
Resolution / Threshold (@ 1Hz)	mg max.	< 0.1	< 0.6
Non linearity	% of FS max.	< 0.8	< 0.9
	g max.	< 0.02	< 0.09
Bandwidth [4]	Hz	0 to ≥ 800	0 to ≥ 600
Noise spectral density in band	µV/√Hz typ.	7	7
[0 ; 9kHz)	max.	< 18	< 18
Resonant frequency	kHz	1.4	3.7

[1]: One year stability defined according to IEEE 528-2001: turn on / turn on, storage at -55°C and 85°C, -40°C to 125°C T cycling, -55°C to 85°C unpowered harass, vibration and shock

[2]: Temperature coefficients are specified for a range of -40°C to 20°C, where temperature behavior is typically linear.

[3]: The bandwidth is defined as the frequency band for which the sensitivity has decreased by less than 3dB.

**Environmental**
**MS7002.3**
**MS7010.3**

Operating temperature range	-40°C to +125°C (-40°F to 255°F)
Reliability	Results based on MIL-HDBK-217, notice 2, are available on request.
Shock resistance	10'000 g (0.2ms half-sine period, shocks in each direction o, p, i)
Recovery time	< 1ms (1000g, half-sine period 1ms, shocks in direction i)
Vibration	20 g rms, 20-2000 Hz (random noise, 30 minutes in each direction o, p, i)
TO8 sealing	The product has been qualified according to MIL-STD-883-E. Hermetic sealing is qualified at 5·10 <sup>-8</sup> atm·cm <sup>3</sup> /s
ESD sensitivity	Class 2 (requirements MIL-STD-883-E, 1 Method 3015.7), HBM 2kV
Note:	- TO8 must be tightly fixed to the PCB, using the bottom of the housing as reference plan for axis alignment. - Excessive stress to housing and extreme soldering conditions may affect the specifications

**Electrical**

Input voltage (VDD – VSS)	2.5 to 5.5 VDC. The standard voltage for calibration is 3.0 VDC.
Input voltage stability	To prevent any un-calibrated output after reset, rapid jumps of the power supply larger than 0.25V must be avoided
Output voltage range	From 0.5 to 2.5 VDC @ 3.0 VDC input voltage (1.5 V ± 5mV at 0g)
Operating current consumption	< 200 µA @ 3.0 VDC
Initialization & reset current consumption	Typ. 700 µA (max. 1000 µA) @ 3.0 VDC during the initialization phase (less than 50 ms at room temperature)
Reset	Reset can only be done by a complete switch off of VDD
Impedance of external components	Min. 10 kΩ at Vout (pin 2) and VAGND (pin 5) Max. 50 pF at Vout (pin 2) and Max. 100 µF at VAGND (pin 5)

**Physical**

Hermetically sealed TO8, 12 pins housing

Weight	Typ. 2.6 grams
Size	Max. Ø 15.55 mm x 3.9 mm height without pins (0.61 inch Ø x 0.15 inch height without pins)

**Block diagram and electrical connections**

It is necessary to use decoupling capacitors [C] of 1µF each between VDD and VAGND and between VAGND and VSS, located as close as possible from the accelerometer. COG or X7R @ 5% capacitor types are recommended. The VAGND track should be also as short as possible. For low noise operation, the case (pin 1) should be connected to the system ground.

An external capacitor C<sub>G</sub> can be added to reduce the output bandwidth of the sensor. See the Application Note "Bandwidth control and resolution improvement", available on our web site for more details. It is anyway recommended to use this option only for development purposes. In production, an external filter will be much more stable over temperature and over time.

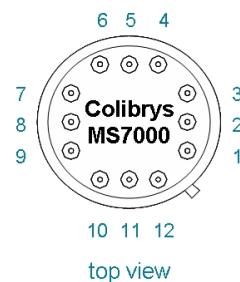
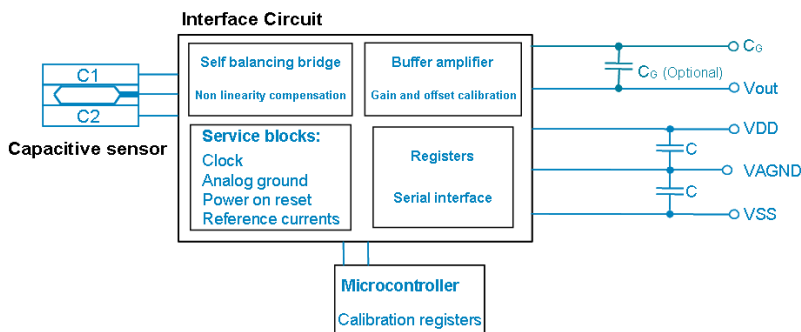

Pin	Description	Remarks
1	NC	Not connected
2	Vout	Accelerometer output signal
3	CG	Bandwidth adjustment
4	VSS	Ground
5	VAGND	Accelerometer output reference voltage(VDD/2)
6	VDD	Power supply
7	NC	Not connected
8	NC	Not connected
9	VPP (Colibrys internal calibration pin)	<b>Must</b> be connected to VSS
10	SDA (Colibrys internal calibration pin)	<b>Must</b> be connected to VSS
11	SCK (Colibrys internal calibration pin)	<b>Must</b> be connected to VSS
12	NC	Not connected

A detailed MS7000 Product Description (30D.MS7X.x.xx.xx) and further Application Notes are available on demand or on our web site. In order to provide an ideal support to our customers, our

standard MS7000 products are available worldwide through a wide network of distributors and agents or directly at Colibrys. Do not hesitate to access our web site for precise contacts or directly Colibrys in Europe or in US for more details.