

MEMS Capacitive Accelerometers

## Data sheet

# SF2005S.A / SF2005SN.A

30S.SF2005A.F.09.10

### Features

**Very low noise level of 800 ng<sub>rms</sub>/√Hz**  
**Wide dynamic range of 111 dB (100Hz BW)**  
**DC to 1000Hz frequency response**  
**± 4g linear output**  
**Analog servo accelerometer**  
**Self test input**

### Applications

**Seismic sensing**      Structure / building monitoring  
 Industrial / process control  
 Strong motion  
 Geophysics  
 Railway technology

### Description

The SiFlex™ SF2005 accelerometer has been designed and developed by Colibrys for “strong motion” structure monitoring applications. This MEMS capacitive product is one of the best in class for seismic and vibration sensing when extreme low noise measurement is required at lower price point. Features such as wide dynamic range, excellent bandwidth, low distortion, high shock tolerance, and thermal stability make it ideal for applications such as building monitoring, industrial and process control or structure monitoring.

The SF2005 operates from a bipolar power supply voltage that can range from ± 6V to ± 15V with a typical current consumption of 12mA at ± 6V. The full linear acceleration range is ± 4g with a corresponding sensitivity of 0.8V/g. The SF2005S and SF2005SN can operate over a wide temperature range from -40°C to +85°C and can withstand a shock of up to 1500g without performance degradation. The frequency response over the full scale range is DC to > 1000Hz.

Full scale range	± 4g (with oscillator)	± 4g (without oscillator)
Products	<b>SF2005S.A</b>	<b>SF2005SN.A</b>

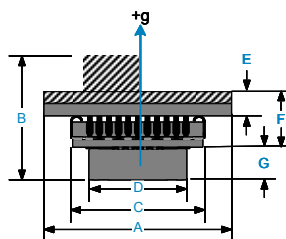
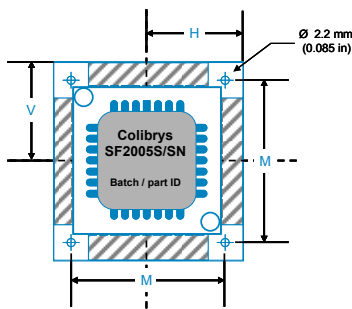

### Typ. values

	Inch	mm
A	0.98	25.0
B	0.57	14.5
C	0.67	17.4
D	0.45	11.5
E	0.07	1.7
F	0.22	5.6
G	0.10	2.6
H	0.49	12.5
M	0.78	19.8
V	0.49	12.5

### Specifications

All values are specified at +20°C (+68°F) and ±6 to ±15VDC supply voltage, unless otherwise stated

	Units	SF2005S.A / SF2005SN.A
Linear output range	g peak	± 4
Sensitivity	V/g (differential)	0.8 ± 0.08 (1.6 ± 0.16)
Frequency response [1]	Hz	DC to > 1000
Dynamic range (100 Hz BW)	dB typ. (min.)	111 (106)
Noise (10 to 1000 Hz)	ng <sub>rms</sub> /√Hz typ. (max.)	800 (1400)
Cross-axis rejection	dB	> 40
Shock limit (0.5 ms ½ sine)	g peak	> 1500
Operating temperature range	°C	-40 to +85
Sensitivity temperature coefficient	ppm/°C (re: ±1g) typ.	-200
DC offset	mg max.	± 300
Input Resistance of Offset adjustment pin	KΩ	10
Offset thermal coefficient	mg/°C (re: ±1g) typ. (min. / max.)	-0.6 (-1 / 0)
Linearity error	% (over ± 1g range)	< 1.25
Input voltage	Volts DC	± 6 to ± 15
Quiescent current @ 6 VDC	mA typ.	11.6

[1]: The bandwidth is defined as the frequency band for which the sensitivity has decreased by less than 3dB.

### Block diagram and electrical connections

Both the (+) and (-) power supplies must be applied simultaneously to the input pins (within 50 ms). The power supply should have less than 100  $\mu\text{V}/\sqrt{\text{Hz}}$  noise in order to avoid the possibility of adding noise to the output of the sensor. The ASIC and on-board electronics operate on  $\pm 5\text{V}$  DC provided by internal power conditioning circuitry, reducing the effects of power supply variations on sensor operation. The input power supply connections are reverse polarity protected by a diode bridge. Should reverse polarity power be applied, the unit will self-correct and start normally.

The output of the Si-Flex accelerometer is fully buffered and ready to connect to common inputs found on many analog to digital converters, oscilloscopes and digital multi-meters. The nominal output impedance for the Si-Flex accelerometers is typically 10 Ohms. The connector reference for the SF2005 is a Samtec part no. FTSH-105-01-L-DV-K-P-TR (Header, 2X5, 1.27mm (0.05 in), SMD).

**Electrostatic discharge (ESD) damage** can occur when Si-Flex accelerometers are improperly handled,

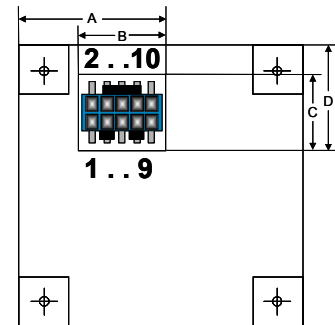
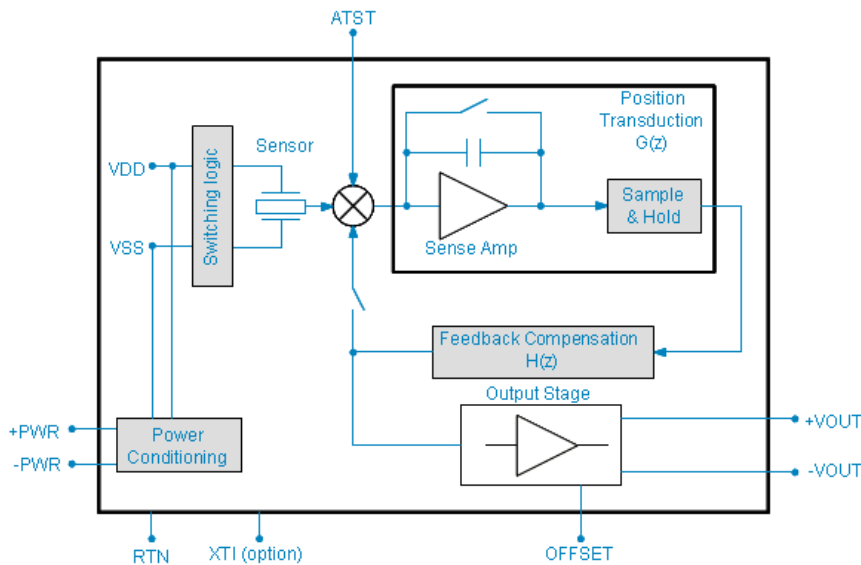

Typ. values	Inch	mm
A	0.49	12.2
B	0.24	6.2
C	0.20	5.1
D	0.36	9.2

### Electrical connections

PJ1-1	-Vout	Inverted output signal
PJ1-2	+Vout	Output signal
PJ1-3	ATST *	Sensor self test input
PJ1-4, PJ1-8	RTN *	Signal return (common)
PJ1-5	OFFSET *	Used to remove DC offset
PJ1-6	XTI *	Oscillator input. N/C for SF2005S
PJ1-7	RTN	Return
PJ1-9	-PWR	Negative power supply
PJ1-10	+PWR	Positive power supply

\* : see SiFlex™ product description for more details

A detailed SiFlex™ Product Description (30D.SFx.x.xx.xx) and further Application Notes are available on demand or on our web site. In order to provide an ideal support to our customers, our standard SF2005S.A and SF2005SN.A products are available worldwide through a wide network

of distributors and agents or directly at ColibrYS. Do not hesitate to access our web site for precise contacts or directly ColibrYS in Europe or in US for more details.