

### Definitions & Glossary

A definition of all symbols currently used in this document is given hereafter

VDD, VSS	[V]	Voltages at the power supply connections (VSS=0, 2.5≤VDD≤5.5)
Vout	[V]	Sensor output voltage
VAGND	[V]	Half of the power supply; it corresponds to the output voltage at zero g
A <sub>FS</sub>	[g]	Full scale range of the acceleration in the input axis (z) direction. The sensor operates to specification within the total range: $-A_{FS} \leq A_i \leq +A_{FS}$
A <sub>i</sub>	[g]	Acceleration of the input axis (z)
A <sub>p</sub>	[g]	Acceleration of the pendulous axis (y)
A <sub>o</sub>	[g]	Acceleration of the output, pivot or hinge axis (x)

### Glossary of parameters of the Data Sheet

#### g [m/s<sup>2</sup>]

Unit of acceleration, equal to standard value of the earth gravity (Accelerometer specifications and data supplied by Colibrys use 9.80665 m/s<sup>2</sup>)

#### Bias [mg]

The accelerometer output at zero g

#### Bias stability [mg]

Maximum drift of the bias after extreme variation of external conditions (aging, temperature cycles, shock, vibration)

#### Bias temperature coefficient [μg/°C]

Maximum variation of the bias calibration under variable external temperature conditions (slope of the best fit straight line through the curve of bias vs. temperature). Bias Temperature Coefficient is specified between -40°C and +50°C, where temperature behaviour is linear

#### Scale factor sensitivity [mV/g]

The ratio of the change in output (in volts) to a unit change of the input (in units of acceleration); thus given in mV/g

#### Scale factor temperature coefficient [ppm/°C]

Maximum deviation of the scale factor under variable external temperature conditions

#### Temperature sensitivity

Sensitivity of a given performance characteristic (typically scale factor, bias, or axis misalignment) to operating temperature, specified as worst case value over the full operating temperature range. Expressed as the change of the characteristic per degree of temperature change; a signed quantity, typically in ppm/°C for scale factor and g/°C for bias. This figure is useful for predicting maximum scale factor error with temperature, as a variable when modelling is not accomplished

#### Axis alignment [mrad]

The extent to which the accelerometer's true sensitive axis deviates from being perfectly orthogonal to the accelerometer's reference mounting surface when mounted to a flat surface

#### Resolution, Threshold [mg]

Value of the smallest acceleration that can be significantly measured

#### Non-linearity [% of FS]

The maximum deviation of accelerometer output from the best linear fit over the full operating range. The deviation is expressed as a percentage of the full-scale output (+A<sub>FS</sub>).

#### Bandwidth [Hz]

Frequency range from DC to F<sub>-3dB</sub> where the variation of the frequency response is less than -3dB

#### Resonant frequency nominal [kHz]

Typical value of the resonant frequency of the mounted system

#### Noise [μV/√Hz]

Undesired perturbations in the accelerometer output signal, which are generally uncorrelated with desired or anticipated input accelerations

### MEMS Capacitive Accelerometers

## Product Description

### MS9000.D

30D.MS9X.C.12.08

#### General Description

Colibrys MS9000 inertial accelerometer is a new extra small product designed for harsh environment and safety critical applications. This generation of products comes in a LCC20 (8.9mm x 8.9mm) ceramic package and in a variety of g ranges from ±2g to ±200g. These sensors can operate over extended temperature ranges with just a few milli g bias stability guaranteed over extended lifetime. The main advantages of this motion sensor are the long term bias stability, the low vibration rectification error, the low temperature coefficient even without compensation and the low power consumption. This product has passed extensive qualifications and is successfully incorporated in IMU and AHRS for Mil/Aerospace and Land Navigation applications where reliability and long term compliance to specifications are

mandatory requirements.

Standard MS9000 products are available with a full-scale range of ±2g, ±10g, ±30g, ±50g, ±100g and now ±200g (Table 1). Colibrys offers the capability to customize the performance such as shock resistance, vibration rectification error as well as the full-scale range of the products, beyond these standard versions.

#### Product description

The MS9000 product is a MEMS capacitive accelerometer based on a bulk micro-machined silicon element, a low power ASIC for signal conditioning, a micro-controller for storage of compensation values and a temperature sensor (Fig. 1).

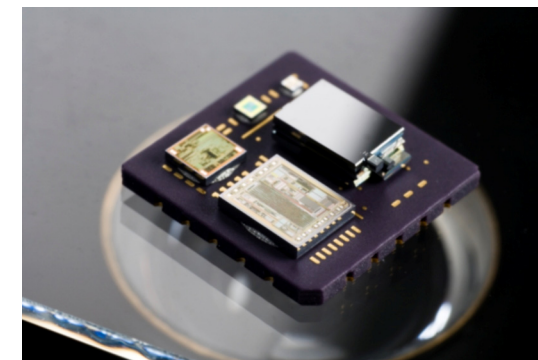

Fig. 1 : Open view of a MS9000 product

It operates from a single power supply voltage (between 2.5V and 5.5V) with low current consumption (< 0.5mA at 5V). The output is ratiometric analog voltage that varies between 0.5V and 4.5V for the full-scale acceleration range at a voltage supply of 5V. The sensor is fully self-contained and packaged in a 20-pin LCC ceramic housing, thus insuring a full hermeticity. It operates over temperature range of -55°C to 125°C and can withstand shocks up to 1000g without performance degradation. Long-term stability of bias and scale factor are typically less than 0.1% of full-scale range. For the ±2g version (MS9002.D), bias temperature coefficient is typically 100 μg/°C and scale factor temperature coefficient 100 ppm/°C without external compensation

Full scale range	± 2g	± 10g	± 30g	± 50g	± 100g	± 200g
LCC20 packaging	<b>MS9002.D</b>	<b>MS9010.D</b>	<b>MS9030.D</b>	<b>MS9050.D</b>	<b>MS9100.D</b>	<b>MS9200.D</b>

#### Accelerometer product features

The core of the accelerometer is the capacitive bulk micro-machined silicon sensor. An assessment has been made to determine which basic technology can at best satisfy the requirements for high performance MEMS accelerometer. Arguments clearly demonstrate that compared to the planar approach ("in plan" displacement of the proof mass), bulk technology ("out of plan" displacement of the proof mass) is the most successful approach to provide high end sensors.

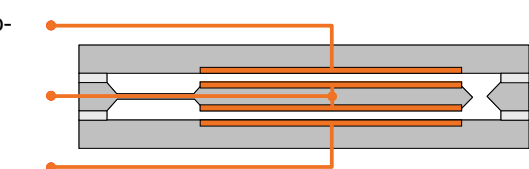

Fig. 2 : Cross section of a Colibrys accelerometer

The fundamental technology for the manufacturing of Colibrys accelerometers is based on the structuring of three silicon wafers. The center wafer supports the proof mass through a spring. This inertial mass is also the center electrode of the capacitive sensor. Upper and lower wafers constitute the fixed electrodes of the sensor (Fig. 2).

The three wafers are bounded together by a process named "Silicon Fusion Bonding" (SFB). This bonding process insures not only a perfect balance between the various wafers of the system but also allows building a hermetic sealed cavity for the spring-mass system (fig. 3). The bonding process is done at high temperature (>1000°C) and at low pressure to ensure an optimal gas damping.

This also allows to avoid any surface contaminant like water molecules in particular and to relax all surface

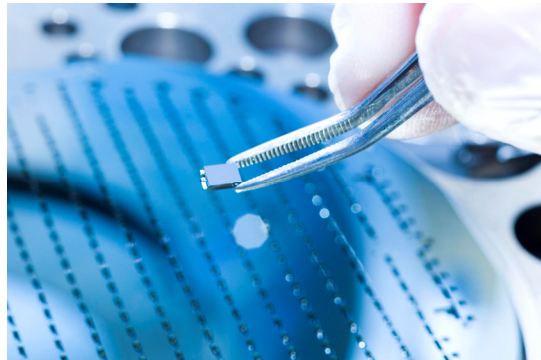

Fig. 3 : MEMS Silicon sensor

### Basic accelerometer operation

The standard calibration voltage for the MS9000.D is (VDD-VSS) = 5V. Therefore, all specifications are valid for this supply voltage, unless otherwise stated. Upon market request, the calibration of the product at a different voltage (i.e. 4.4V) is possible.

Even if calibrated at 5V, the MS9000 can be used with a nominal input voltage, which can vary between 2.5V and 5.5V.

In such a case, the nominal output signal will vary according to the following equation:

$$V_{out} = (VDD - VSS) / 2 + A_i + (K1 \cdot VDD / 5) \quad (1)$$

$$V_{AGND} = (VDD - VSS) / 2 \quad (2)$$

According to this equation <sup>(1)</sup>, the bias and scale factor are ratiometric to the power supply voltage. A reference voltage VAGND is also provided at half of the power supply and corresponds to the output voltage at zero g. All sensors are calibrated to match the ideal response curve in term of offset, gain and non-linearity, within the

### Sensor connections & power supply requirements

The detailed block diagram is given in the next figure (Fig. 4)

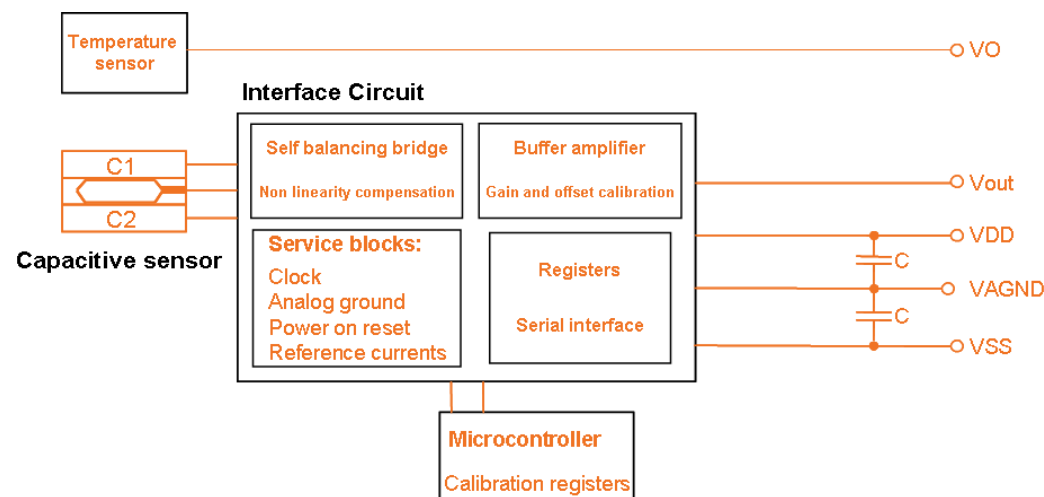

Fig. 4 : Block diagram

It is strongly recommended to use decoupling capacitors [C] of 1µF each between VDD and VAGND and between VAGND and VSS, placed as close as possible from the accelerometer. COG or X7R @ 5% capacitor types are recommended. On top of that, the VAGND track should be as short as possible. Any other setup will directly affect the bias calibration.

stresses that could be present prior bonding. This is essential to avoid any sticking effect of the seismic mass to the fixed electrodes in case of chock for instance. Drift effects of the extraction voltage due to humidity effects and other contaminants are also removed. The measurement range of the “spring – mass” system is adaptable. Variations of open loop measurement ranges are obtained by modifying the thickness of the spring. Under acceleration or tilt, the inertia makes it move between the upper and lower plates and change the values of the capacitors. This differential variation of the sensing capacitors is measured through the interface circuit, which uses a self-balancing capacitor bridge to translate the signal into a calibrated voltage output, using the compensation parameters (offset, gain and non-linearity) that are stored in the microcontroller

specified error margins.

The following model describes each sensor:

$$V_{out} = k_1 \cdot (k_0 + A_i + k_2 A_i^2 + k_3 A_i^3 + k_p A_p + k_o A_o + k_{ip} A_i A_p + k_{io} A_i A_o + E)$$

where

- Ai, Ap and Ao are the accelerations for each axes of the sensor
- i: input axis (z axis)
- p: pendulous axis (y axis)
- o: output axis, also named pivot or hinge axis (x axis)
- K1 is accelerometer scale factor [V/g]
- K0 is bias [g]
- K2 is second order non linearity [g/g<sup>2</sup>]
- K3 is third order non-linearity [g/g<sup>3</sup>]
- Kp is pendulous cross axis non linearity [rad]
- Ko is output cross axis non linearity [rad]
- Kip, Kio are cross-coupling coefficients [rad/g]
- E is the residual noise [g]

At every power-up, the microcontroller transfers the calibration parameters to the ASIC and then goes in a sleep mode. During this initialization phase, which takes less than 50ms, the current consumption goes up to max. 1.5mA @ 5V at room temperature. Then, the normal operating current consumption remains less than 400µA under similar conditions.

If an un-stabilized voltage is used (e.g. a battery), the output voltage has to be divided by the input voltage in order to obtain a calibrated signal according to equation

(1). This normalization can be done for instance, by using the same voltage to power the sensor and to reference the external A/D converter.

Pin	Description	Remarks
4	VDD	Power supply
5	VAGND	Accelerometer output reference voltage(VDD/2)
6	VSS	Ground
7	VO	Temperature sensor output
8	Vout	Accelerometer output signal
16	VPP (Colibrys internal calibration pin)	<b>Must</b> be connected to VSS
17	SCK (Colibrys internal calibration pin)	<b>Must</b> be connected to VSS
18	SDA (Colibrys internal calibration pin)	<b>Must</b> be connected to VSS

Fig. 5 : MS9000.D electrical connections

### Packaging

The packaging is a standard LCC housing with a total of 20 pins.

Sealing process is qualified at 5-10-8 atm·cm<sup>3</sup>/s (requirements MIL-STD-883-E).

The precise dimensions are given in the next figure (Fig. 6) and the weight of the product is typically smaller than 1.5 grams

### Mounting

MS9000 accelerometers must be tightly fixed to the PCB, using the bottom of the housing as reference plan for axis alignment. On the same time excessive stress to housing and soldering conditions may affect specifications. See the Application Note “LCC-48 housing, soldering conditions” for more information about the mounting process of the MS8000 and MS9000. This document is available on demand or on our web site

### ESD

ESD sensitivity: Class 2, per MIL-STD-883-E method 3015.7 requirements (human body model, 2kV)

### Temperature compensation

The MS9000 delivers an output with small temperature sensitivity. It has to be noted that this performance is reached without any temperature calibration. To get even better performances, customers can calibrate the sensor with respect to the temperature given by the internal temperature sensor.

### Quality system

Colibrys is ISO 9001.2000, ISO 14001 and OHSAS 18001 certified; copy of each certificate is available on request

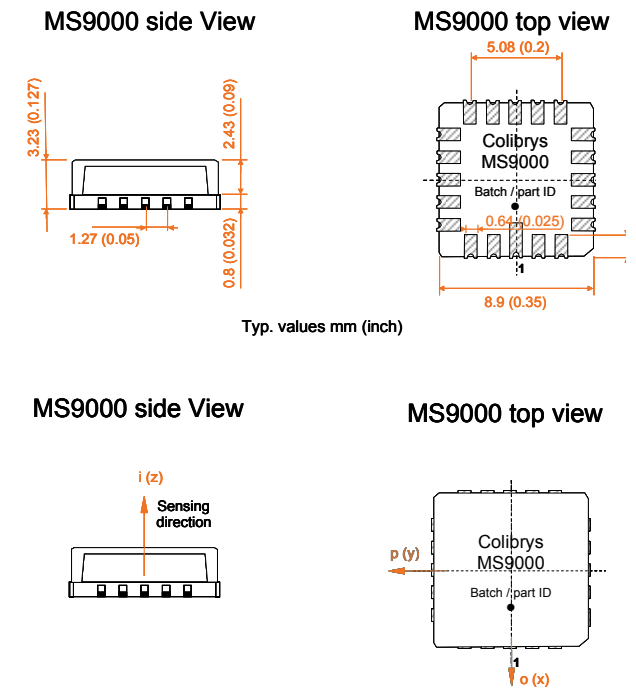

Fig. 6 : MS9000 LCC20 packaging